

# CALCIUM FLAT PLATE

B A T T E R I E S



## Description

The EnerSys DX is an economical multi-cell calcium flat plate battery. The DX unit is optimized for high rate performance. It features EnerSys's time tested Slide-Lock™ post seal design and is best suited for UPS applications. This battery is rated at 100% capacity at initial discharge.

## Features

### Safe

- Cover made from Flame Retardant PVC (UL94, VO/L.O.I.28%).
- Container made from Flame Retardant polycarbonate (UL94, V-0/L.O.I.28%) optional.

### Application

- UPS
- Switchgear

### Economical

- Multi-cell construction requires fewer units, resulting in lower installation costs.

### Performance

- **All battery systems rated at 100% capacity at initial discharge.**
- Expanded capacity - .613 KW to 5.248 KW per cell to 1.67 VPC at the 15 minute rate.
- Energy - optimized for high performance, short duration rates.
- High conductivity/high integrity - lead plated copper terminal posts.
- Footprint - space efficient design reduces footprint requirements.

### Durable

- 20 year life expectancy in float service at 77°F ambient temperature.
- Long life Slide-Lock™ post seal design.

Installation services and preventative maintenance packages available.

**DX**  
**256-1800Ah**  
**0.613 - 5.248kW**

A P P L I C A T I O N S :

**UPS**  
**SWITCHGEAR**

## Specifications

### PLATE THICKNESS:

POSITIVE: .200 inches (5.1mm)  
 NEGATIVE: .130 inches (3.6 mm)

### PLATE SUSPENSION TYPE:

POSITIVE: Bridge hung  
 NEGATIVE: Bottom supported

### CONTAINER:

Styrene Acrylonitrile Copolymer  
 Container made from Flame Retardant polycarbonate (optional).

**COVER:** Made from Flame Retardant PVC (UL94, V-0/L.O.I.28%).

**SEPARATORS:** Microporous plastic

### BOLT CONNECTORS:

Stainless Steel, Standard English Measure, Hex-Head

### INTERUNIT CONNECTORS:

Lead-Plated Copper

### ELECTROLYTE OVER PLATES:

2.88 inches (73.1mm)

### VENT TYPE:

Flame Arrestor, Fused Alumina

### FLOAT VOLTAGE SETTINGS:

ACCEPTABLE MIN/MAX: 2.17/2.26 VPC  
 RECOMMENDED: 2.25 VPC

**SEDIMENT SPACE:** 1.04 inches (26.4 mm)

### POSTS:

Lead-plated copper  
 DX-5 to DX-25 - one positive post and one negative post per cell.  
 DX-27 to DX-35 - two positive posts and two negative posts per cell.

### POST SEAL TYPE:

Slide-Lock™

### SPECIFIC GRAVITY:

1.215 standard (1.250 available upon request)

# AVERAGE CELL PERFORMANCE DATA\* (Discharge Rates in Amperes\*\*)

TYPE	Nom. Ah Cap	8 HR	7 HR	6 HR	5 HR	4 HR	3.5 HR	3 HR	2.5 HR	2 HR	1.5 HR	60 MIN	30 MIN	15 MIN	5 MIN	1 MIN <sup>1</sup> to 1.50 VPC	
<b>1.250 SPECIFIC GRAVITY TO 1.75 END VOLTS PER CELL</b>																	
<b>DX-5B</b>	280	35	40	43	49	58	64	69	82	96	117	156	250	345	479	562	741
<b>DX-7B</b>	400	50	55	62	71	84	93	99	119	140	172	230	372	512	713	838	1100
<b>DX-9B</b>	528	66	72	81	92	109	116	126	154	180	223	301	492	675	941	1112	1451
<b>DX-11B</b>	712	89	102	112	128	152	167	189	213	252	310	407	606	839	1043	1251	2124
<b>DX-13B</b>	832	104	116	128	148	178	195	221	250	299	369	481	722	995	1251	1498	2543
<b>DX-15B</b>	928	116	129	143	166	200	220	251	285	344	426	552	842	1148	1460	1738	2960
<b>DX-17B</b>	1024	128	140	155	183	221	245	279	318	388	481	621	954	1296	1668	1979	3376
<b>DX-19B</b>	1048	131	146	166	192	227	249	283	323	394	489	655	1030	1379	1833	2183	3579
<b>DX-21B</b>	1168	146	163	184	213	252	277	314	359	437	543	800	1185	1600	2146	2446	4140
<b>DX-23B</b>	1280	160	179	203	235	277	305	346	395	481	598	865	1292	1741	2330	2677	4510
<b>DX-25B</b>	1400	175	195	221	256	303	333	377	431	525	652	926	1396	1881	2516	2903	4871
<b>DX-27B</b>	1744	218	243	275	316	378	413	450	531	627	778	1018	1546	2078	2778	3127	5385
<b>DX-29B</b>	1816	227	252	286	330	394	431	466	554	656	819	1077	1649	2215	2957	3453	5741
<b>DX-31B</b>	1872	234	262	297	343	407	445	477	576	681	856	1132	1750	2348	3129	3678	6091
<b>DX-33B</b>	1944	243	270	306	354	419	460	487	595	704	890	1185	1849	2478	3299	3901	6428
<b>DX-35B</b>	1976	247	277	313	363	429	469	495	610	726	923	1237	1946	2605	3463	4123	6761
<b>1.215 SPECIFIC GRAVITY TO 1.75 END VOLTS PER CELL</b>																	
<b>DX-5</b>	256	32	36	39	45	53	58	63	75	87	107	142	227	314	436	510	673
<b>DX-7</b>	368	46	50	56	64	77	84	90	109	127	156	209	339	466	648	761	1000
<b>DX-9</b>	480	60	65	73	83	99	106	114	141	164	203	274	447	614	856	1011	1319
<b>DX-11</b>	648	81	92	102	116	139	151	172	194	229	282	371	551	762	948	1138	1931
<b>DX-13</b>	752	94	106	116	135	161	178	201	228	272	335	437	656	905	1138	1360	2312
<b>DX-15</b>	848	106	117	130	150	181	200	228	259	313	387	501	765	1043	1327	1580	2691
<b>DX-17</b>	928	116	127	141	167	201	223	254	289	353	437	565	867	1178	1517	1798	3069
<b>DX-19</b>	952	119	133	150	175	207	227	257	294	358	444	596	936	1254	1666	1984	3253
<b>DX-21</b>	1056	132	148	168	194	229	252	286	326	398	494	728	1078	1454	1951	2321	3764
<b>DX-23</b>	1168	146	163	184	213	252	277	314	359	437	543	787	1175	1583	2118	2433	4098
<b>DX-25</b>	1272	159	178	201	233	275	303	343	392	477	593	843	1270	1710	2287	2638	4428
<b>DX-27</b>	1592	199	220	249	287	344	375	409	482	569	707	925	1406	1889	2526	2931	4896
<b>DX-29</b>	1656	207	229	260	300	358	392	432	503	597	744	979	1499	2013	2688	3139	5220
<b>DX-31</b>	1696	212	238	270	312	371	404	434	524	619	778	1029	1591	2135	2845	3344	5537
<b>DX-33</b>	1760	220	245	277	322	381	418	442	540	640	810	1078	1681	2253	2999	3546	5843
<b>DX-35</b>	1800	225	252	285	330	390	427	450	555	660	839	1124	1769	2369	3148	3748	6146

\*Ampere values listed represent 100% of the initial capacity.

\*\*At 77°F (25°C) includes intercell connector drop.

<sup>1</sup>One minute rates to 1.50 VPC and 1.75 VPC should only be used for short circuit calculations and not as performance data.

<sup>2</sup>Nominal Amp-Hour capacity at the 8 hour rate.

All data subject to change without notice.

### Average Cell Performance Data\* Discharge Rates in KW Per Cell\*\*

TYPE	1.215 SPECIFIC GRAVITY										
	5 MIN	10 MIN	15 MIN	20 MIN	25 MIN	30 MIN	45 MIN	60 MIN	90 MIN	120 MIN	180 MIN
<b>DX-5B</b>	0.850	0.712	0.619	0.557	0.503	0.454	0.348	0.286	0.214	0.176	0.128
<b>DX-7B</b>	1.261	1.058	0.918	0.827	0.748	0.674	0.519	0.422	0.314	0.257	0.184
<b>DX-9B</b>	1.665	1.397	1.210	1.095	0.988	0.890	0.738	0.552	0.408	0.331	0.234
<b>DX-11B</b>	2.145	1.660	1.503	1.393	1.199	1.098	0.962	0.748	0.568	0.464	0.351
<b>DX-13B</b>	2.815	1.970	1.783	1.591	1.433	1.307	1.028	0.884	0.674	0.549	0.411
<b>DX-15B</b>	2.983	2.275	2.055	1.846	1.672	1.525	1.149	1.014	0.779	0.633	0.476
<b>DX-17B</b>	2.952	2.572	2.201	1.904	1.729	1.319	1.179	0.880	0.713	0.519	
<b>DX-19B</b>	3.240	2.800	2.471	2.231	2.040	1.865	1.379	1.202	0.894	0.724	0.526
<b>DX-21B</b>	3.788	3.229	2.860	2.572	2.339	2.143	1.701	1.466	0.994	0.804	0.584
<b>DX-23B</b>	4.120	3.518	3.113	2.801	2.549	2.335	1.838	1.586	1.093	0.885	0.644
<b>DX-25B</b>	4.443	3.802	3.363	3.027	2.756	2.523	1.969	1.698	1.192	0.965	0.701
<b>DX-27B</b>	4.916	4.211	3.722	3.352	3.057	2.800	2.134	1.868	1.423	1.152	0.837
<b>DX-29B</b>	5.231	4.491	3.966	3.572	3.262	2.987	2.276	1.977	1.498	1.206	0.866
<b>DX-31B</b>	5.537	4.763	4.206	3.776	3.464	3.169	2.111	2.079	1.565	1.252	0.887
<b>DX-33B</b>	5.837	5.028	4.439	4.004	3.661	3.348	2.468	2.177	1.629	1.295	0.905
<b>DX-35B</b>	6.127	5.289	4.667	4.218	3.854	3.524	2.677	2.271	1.689	1.335	0.920
<b>TO 1.67 END VOLTS PER CELL</b>											
<b>DX-5B</b>	0.927	0.774	0.674	0.593	0.527	0.472	0.358	0.298	0.218	0.176	0.128
<b>DX-7B</b>	1.378	1.148	1.001	0.882	0.784	0.701	0.529	0.441	0.320	0.257	0.184
<b>DX-9B</b>	1.822	1.514	1.320	1.168	1.034	0.924	0.738	0.579	0.416	0.331	0.234
<b>DX-11B</b>	2.199	1.930	1.661	1.449	1.284	1.151	0.879	0.761	0.579	0.464	0.351
<b>DX-13B</b>	2.639	2.286	1.962	1.720	1.525	1.361	1.040	0.903	0.687	0.549	0.411
<b>DX-15B</b>	3.079	2.633	2.254	1.982	1.764	1.576	1.181	1.042	0.795	0.633	0.476
<b>DX-17B</b>	3.519	2.969	2.537	2.241	2.001	1.768	1.332	1.177	0.898	0.713	0.519
<b>DX-19B</b>	3.840	3.206	2.778	2.468	2.199	1.951	1.418	1.261	0.914	0.724	0.526
<b>DX-21B</b>	4.417	3.722	3.231	2.855	2.537	2.262	1.721	1.491	1.014	0.804	0.584
<b>DX-23B</b>	4.813	4.052	3.516	3.108	2.764	2.484	1.863	1.619	1.115	0.885	0.644
<b>DX-25B</b>	5.201	4.371	3.743	3.335	2.985	2.688	2.008	1.742	1.216	0.965	0.701
<b>DX-27B</b>	5.768	4.839	4.200	3.719	3.308	2.943	2.195	1.925	1.451	1.152	0.837
<b>DX-29B</b>	6.151	5.156	4.473	3.963	3.527	3.136	2.323	2.045	1.528	1.206	0.866
<b>DX-31B</b>	6.525	5.462	4.737	4.200	3.739	3.322	2.443	2.160	1.596	1.252	0.887
<b>DX-33B</b>	6.895	5.763	4.996	4.435	3.950	3.506	2.565	2.273	1.662	1.295	0.905
<b>DX-35B</b>	7.255	6.056	5.248	4.661	4.154	3.685	2.677	2.381	1.723	1.335	0.920
<b>TO 1.63 END VOLTS PER CELL</b>											
<b>DX-5B</b>	0.939	0.791	0.688	0.602	0.532	0.473	0.358	0.298	0.218	0.176	0.128
<b>DX-7B</b>	1.397	1.174	1.022	0.896	0.791	0.702	0.529	0.441	0.320	0.257	0.184
<b>DX-9B</b>	1.844	1.550	1.349	1.190	1.069	0.977	0.758	0.579	0.416	0.331	0.234
<b>DX-11B</b>	2.304	1.972	1.696	1.478	1.301	1.154	0.879	0.761	0.579	0.464	0.351
<b>DX-13B</b>	2.765	2.347	2.005	1.757	1.552	1.375	1.040	0.903	0.687	0.549	0.411
<b>DX-15B</b>	3.225	2.716	2.305	2.021	1.787	1.581	1.181	1.042	0.795	0.633	0.476
<b>DX-17B</b>	3.686	3.078	2.595	2.286	2.029	1.795	1.332	1.177	0.898	0.713	0.519
<b>DX-19B</b>	4.031	3.360	2.875	2.538	2.238	1.958	1.418	1.261	0.912	0.724	0.526
<b>DX-21B</b>	4.631	3.913	3.314	2.909	2.582	2.283	1.721	1.491	1.014	0.804	0.584
<b>DX-23B</b>	5.047	4.214	3.610	3.176	2.807	2.483	1.863	1.619	1.115	0.885	0.644
<b>DX-25B</b>	5.456	4.552	3.888	3.426	3.032	2.679	2.008	1.742	1.216	0.965	0.701
<b>DX-27B</b>	6.047	5.042	4.323	3.806	3.362	2.955	2.195	1.925	1.451	1.152	0.837
<b>DX-29B</b>	6.451	5.385	4.609	4.061	3.586	3.156	2.323	2.045	1.528	1.206	0.866
<b>DX-31B</b>	6.848	5.712	4.890	4.309	3.803	3.341	2.443	2.160	1.596	1.252	0.887
<b>DX-33B</b>	7.235	6.033	5.163	4.564	4.019	3.525	2.565	2.273	1.662	1.295	0.905
<b>DX-35B</b>	7.615	6.347	5.430	4.794	4.228	3.700	2.677	2.381	1.723	1.335	0.920
<b>TO 1.60 END VOLTS PER CELL</b>											
<b>DX-5B</b>	0.951	0.797	0.692	0.605	0.533	0.473	0.358	0.298	0.218	0.176	0.128
<b>DX-7B</b>	1.411	1.186	1.028	0.899	0.792	0.702	0.529	0.441	0.320	0.257	0.184
<b>DX-9B</b>	1.862	1.568	1.358	1.194	1.071	0.977	0.758	0.579	0.416	0.331	0.234
<b>DX-11B</b>	2.368	2.010	1.740	1.497	1.307	1.154	0.879	0.761	0.579	0.464	0.351
<b>DX-13B</b>	2.841	2.392	2.047	1.779	1.559	1.375	1.040	0.903	0.687	0.549	0.411
<b>DX-15B</b>	3.315	2.769	2.355	2.055	1.801	1.581	1.181	1.042	0.795	0.633	0.476
<b>DX-17B</b>	3.789	3.139	2.653	2.325	2.046	1.795	1.332	1.177	0.898	0.713	0.519
<b>DX-19B</b>	4.149	3.445	2.926	2.574	2.256	1.958	1.418	1.261	0.912	0.724	0.526
<b>DX-21B</b>	4.769	3.937	3.350	2.931	2.583	2.283	1.721	1.491	1.014	0.804	0.584
<b>DX-23B</b>	5.195	4.294	3.653	3.197	2.815	2.483	1.863	1.619	1.115	0.885	0.644
<b>DX-25B</b>	5.618	4.644	3.985	3.474	3.044	2.679	2.008	1.742	1.216	0.965	0.701
<b>DX-27B</b>	6.226	5.155	4.381	3.845	3.381	2.965	2.195	1.925	1.451	1.152	0.837
<b>DX-29B</b>	6.643	5.503	4.677	4.106	3.608	3.156	2.323	2.045	1.528	1.206	0.866
<b>DX-31B</b>	7.049	5.842	4.965	4.363	3.831	3.341	2.443	2.160	1.596	1.252	0.887
<b>DX-33B</b>	7.447	6.179	5.249	4.616	4.051	3.525	2.565	2.273	1.662	1.295	0.905
<b>DX-35B</b>	7.837	6.508	5.527	4.862	4.262	3.700	2.677	2.381	1.723	1.335	0.920

\*KW Values listed represent 100% of the initial capacity. \*\*At 77°F (25°C) includes intercell connector drop. All data subject to change without notice.

TYPE	1.215 SPECIFIC GRAVITY										
	5 MIN	10 MIN	15 MIN	20 MIN	25 MIN	30 MIN	45 MIN	60 MIN	90 MIN	120 MIN	180 MIN
<b>DX-5</b>	0.772	0.647	0.562	0.506	0.457	0.413	0.316	0.260	0.195	0.160	0.116
<b>DX-7</b>	1.146	0.962	0.834	0.751	0.680	0.613	0.472	0.383	0.285	0.234	0.167
<b>DX-9</b>	1.513	1.269	1.099	0.995	0.898	0.809	0.671	0.502	0.371	0.301	0.213
<b>DX-11</b>	1.676	1.508	1.365	1.211	1.089	0.998	0.784	0.680	0.516	0.422	0.319
<b>DX-13</b>	2.012	1.790	1.620	1.446	1.302	1.187	0.934	0.803	0.613	0.499	0.374
<b>DX-15</b>	2.347	2.067	1.868	1.678	1.520	1.386	1.045	0.921	0.708	0.575	0.433
<b>DX-17</b>	2.682	2.338	2.109	1.908	1.730	1.571	1.199	1.036	0.800	0.648	0.472
<b>DX-19</b>	2.944	2.545	2.245	2.027	1.854	1.695	1.253	1.092	0.810	0.658	0.478
<b>DX-21</b>	3.442	2.934	2.598	2.337	2.125	1.947	1.546	1.332	0.904	0.731	0.531
<b>DX-23</b>	3.743	3.197	2.829	2.545	2.316	2.122	1.670	1.441	0.994	0.805	0.585
<b>DX-25</b>	4.037	3.455	3.056	2.751	2.504	2.293	1.789	1.543	1.084	0.877	0.637
<b>DX-27</b>	4.467	3.826	3.362	3.046	2.778	2.545	1.939	1.698	1.124	0.947	0.761
<b>DX-29</b>	4.754	4.081	3.604	3.242	2.964	2.714	2.023	1.796	1.262	1.096	0.787
<b>DX-31</b>	5.031	4.328	3.822	3.432	3.148	2.880	1.918	1.889	1.423	1.138	0.806
<b>DX-33</b>	5.305	4.569	4.033	3.639	3.327	3.043	2.242	1.978	1.481	1.177	0.823
<b>DX-35</b>	5.568	4.806	4.241	3.833	3.502	3.202	2.433	2.063	1.535	1.214	0.836
<b>TO 1.67 END VOLTS PER CELL</b>											
<b>DX-5</b>	0.843	0.703	0.613	0.539	0.479	0.429	0.325	0.271	0.198	0.160	0.116
<b>DX-7</b>	1.253	1.044	0.910	0.802	0.712	0.637	0.480	0.401	0.291	0.234	0.167
<b>DX-9</b>	1.655	1.376	1.200	1.061	0.940	0.840	0.688	0.526	0.378	0.301	0.213
<b>DX-11</b>	1.998	1.754	1.509	1.317	1.167	1.046	0.799	0.692	0.527	0.422	0.319
<b>DX-13</b>	2.398	2.078	1.783	1.563	1.386	1.237	0.945	0.821	0.625	0.499	0.374
<b>DX-15</b>	2.798	2.392	2.048	1.801	1.603	1.432	1.074	0.947	0.722	0.575	0.433
<b>DX-17</b>	3.198	2.698	2.305	2.036	1.818	1.624	1.210	1.069	0.816	0.648	0.472
<b>DX-19</b>	3.490	2.913	2.524	2.243	1.998	1.773	1.289	1.146	0.829	0.658	0.478
<b>DX-21</b>	4.014	3.382	2.936	2.594	2.305	2.056	1.564	1.355	0.922	0.731	0.531
<b>DX-23</b>	4.374	3.682	3.195	2.824	2.511	2.239	1.693	1.471	1.014	0.805	0.585
<b>DX-25</b>	4										

# Capacities - Dimensions - Weights

TYPE*	NOM. Ah CAP.	OVERALL DIMENSIONS						WEIGHTS - VOLUMES							
		L**		W		H		UNPACKED		DOMESTIC PACKED		ELECTROLYTE ONLY 1.215 S.G.			
		in	mm	in	mm	in	mm	lbs	kgs	lbs	kgs	lbs	kgs	gal	L
4DX-5	256	9.50	241	16.00	406	22.00	558	256.0	116.4	263.0	119.5	80.0	36.4	7.5	28.4
4DX-7	368	9.50	241	16.00	406	22.00	558	303.0	137.7	312.0	141.8	70.0	31.8	6.7	25.4
4DX-9	480	9.50	241	16.00	406	22.00	558	353.0	160.5	363.0	152.7	63.0	28.6	6.0	22.7
4DX-11	648	16.70	424	16.00	406	22.68	576	507.0	230.5	522.0	237.3	146.0	66.4	14.0	53.0
4DX-13	752	16.70	424	16.00	406	22.68	576	557.0	253.2	573.0	260.4	138.0	62.7	13.0	49.2
4DX-15	848	16.70	424	16.00	406	22.68	576	606.0	275.5	624.0	283.6	130.0	59.1	12.5	47.3
4DX-17	928	16.70	424	16.00	406	22.68	576	656.0	298.2	675.0	306.8	122.0	55.4	11.8	44.7
2DX-19	952	9.50	241	16.00	406	22.68	576	373.0	169.5	384.0	174.5	67.0	30.4	6.5	24.6
2DX-21	1056	12.12	308	16.00	406	22.68	576	448.0	203.8	463.3	210.6	93.3	42.4	8.97	33.9
2DX-23	1168	12.12	308	16.00	406	22.68	576	473.0	215.1	489.3	222.4	89.3	40.6	8.58	32.4
2DX-25	1272	12.12	308	16.00	406	22.68	576	499.3	227.0	515.3	234.2	85.3	38.8	8.20	31.0
2DX-27	1592	16.70	424	16.00	406	22.68	576	587.0	266.8	604.0	274.5	143.0	65.0	13.7	51.8
2DX-29	1656	16.70	424	16.00	406	22.68	576	613.0	278.6	632.0	287.2	139.0	63.1	13.3	50.3
2DX-31	1696	16.70	424	16.00	406	22.68	576	638.0	290.0	657.0	298.6	135.0	61.4	12.9	48.8
2DX-33	1760	16.70	424	16.00	406	22.68	576	663.0	301.4	682.0	310.0	130.0	59.1	12.5	47.3
2DX-35	1800	16.70	424	16.00	406	22.68	576	680.0	309.0	700.0	318.2	126.0	57.3	12.1	45.8

\* Suffix Number denotes Total Plates Per Cell. Prefix number indicates total cells per jar.

\*\* 0.25 inches must be added between units for spacing purposes when calculating total battery length.

All data subject to change without notice

## Accessories

†CELL NUMBER SET	1-12	802360
	1-24	802361
	1-60	802362
	1-120	802363
	1-240	802364
	1-300	802365
†PORTABLE HYDROMETER		81332
†HYDROMETER - WALL MOUNT		27717
†THERMOMETER		88330
(Portable or Flame Arrestor Mounting)		
FLAME ARRESTOR (Supplied With Each Cell)		96300
†Included with each system		

## Slide-Lock™ Post Seal

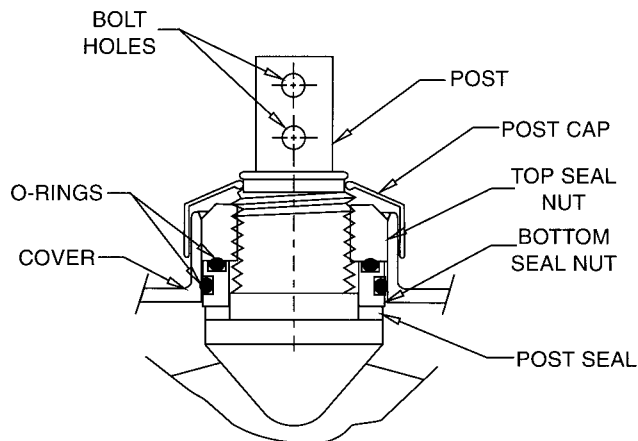

**NOTE:** All inter-cell, inter-tier, inter-step, end-to-end inter-rack, back-to-back inter-rack connectors, terminal lugs, and terminal plates are included with every battery. Across-aisle inter-rack connectors are not included.



Represented by:

When ordering new batteries, also remember to properly recycle your old lead batteries. Federal and state regulations require lead-acid batteries be recycled. EnerSys Inc.'s nationwide service organization can arrange pickup, transportation to and recycling at any one of our company affiliated smelters. Call 1-800-972-7372 for more information.

24 Hour Service or Repair, call:  
1-800-423-9602 (U.S.)



**Global Headquarters:** P.O. Box 14145, Reading, PA 19612-4145  
1-610-208-1991 • 1-800-538-3627  
FAX 1-610-372-8613

**US Sales Offices**  
Eastern Region: 1-800-346-4402 • 1-215-491-3700  
Western Region: 1-510-423-4667 • 1-562-949-4266

**Regional Sales Offices**  
EnerSys Canada: 1-905-790-1212  
ESB de Mexico SA DE: 52-818-329-6405

EnerSys Inc. has locations worldwide to serve your needs: for additional information please visit our website at [www.enersysinc.com](http://www.enersysinc.com) or contact us at 1-800-538-3627.